

## VBS 2026 STUDENT & ADULT BASE CONFERENCE PLAN (1 ½ HOURS)

### Purpose Statement

This 90-minute plan equips church leaders with the training and tools they need to lead Lifeway's Illumination Station® VBS for students and adults.

### Needed Resources

- *VBS Student Starter Kit* (005853487) — Display Student Kit Items 1–3, 9, 11, 13, and 15 and the Session 4 printable “Sharing the Gospel with Students” on the focal wall.
- *VBS Adult Starter Kit* (005853498) — Pull Adult Kit Items 2–9 and 12.
- VBS 2026 Printable Items — Printable items are included for download using the redemption codes in both the Student and Adult Starter Kits. Print all items, place in a binder, and display.
- *VBS 2026 Administrative Guide* (005853431)
- *VBS 2026 Decorating Made Easy* (005853432)
- *VBS 2026 Recreation Rotation Leader Cards* (005853426)
- *VBS 2026 Visual Pack* (005853615)
- *VBS 2026 Supersized Backdrop* (005853613) or *VBS 2026 Super Duper Sized Backdrop* (005853614) (depending on room size)
- *VBS 2026 String Flags* (005853579)
- *VBS 2026 Whirleys* (005853580)
- *VBS 2026 Floor Prints* (005853578)
- *VBS 2026 Music for Kids CD* (005853488) or digital album (005853746)
- *VBS 2026 Glitter Beach Balls* (005853774)
- Item 1: “Flashlights” — Print two copies on cardstock and cut out each flashlight. Tape the first three in random places around the room in plain sight. Tape the “Phew!” flashlight behind a dry erase board or somewhere out of sight for only you to find.
- CSB Apologetics Study Bible for Students (005787293)
- CSB Apologetics Study Bible, Revised and Updated (005854698)
- CSB Connecting Scripture New Testament (005851822)
- Dry erase board or large sticky note easel pad
- Dry erase markers
- Tape
- 4 tabletop display stands — Use to prop up items to be clearly seen on tables.
- TV or projector for slides
- CD Player or Bluetooth speaker

### Room Setup

Hang the posters and kit items on the focal wall, extending to adjacent walls if needed. Decorate the room with VBS 2026 decorations. Center a TV or projector screen on the focal wall. Cover two tables with *VBS 2026 Tablecloths* and position them on either side of the screen. Use display stands (or other creative props) to elevate and showcase the Starter Kit items and any additional materials you want to highlight. Hang the *VBS 2026 Whirleys* from the ceiling along with other elements from *VBS 2026 Decorating Made Easy* to help create the atmosphere for Illumination Station. Arrange chairs in a semicircle, leaving enough space between the seating and tables for movement, games, and activities.

## Teaching Steps

### 1. Let's Begin (5 minutes)

- Play Illumination Station music as conferees as they arrive.
- Introduce yourself and welcome conferees. Say: "I hope you are ready to make your VBS SHINE for all ages this year! Let's take a moment to get to know each other better."
- Ask: "Would you rather have glow-in-the-dark *footsteps* wherever you walk or your face shine bright when you're happy?" Allow as many responses as time allows. This can help stimulate discussion for later.
- Say: "That was so fun to hear how you can leave a GLOWING impression for all to see! Speaking of that, did you know that's what VBS is all about? No matter your age, you we can be a LIGHT for Jesus and help others see that Jesus is the Light of the world!"
- Teach the motto (Jesus is the Light of the world) with a call back response. Call out "Jesus is ..." and lead conferees to respond, as loudly as possible with "...the Light of the world!" Lead the group to do the call and response a few times.
  - Optional: Reverse the prompts by guiding the group to begin, or lead the left side of the room to say it for the right side of the room to respond. Be creative and encourage participation and volume!
- Say: "Whew! You sure know how to be loud! One of the best parts of VBS is that it's not just for kids. We can create a totally awesome experience for teenagers and adults too! Since we are combined, let's learn who we are serving—students, adults, or both." Prompt the conferees to perform the following actions:
  - If they are leading students, guide them to do their best disco dance moves.
  - If they are leading adults, guide them to live in the spotlight by miming their best Oscar award winning performance.
  - If they are serving in both, lead them to combine both actions to the best of their ability.

### 2. Does This Matter? (10 minutes)

- Say: "That was so much fun! You guys have some great moves, but before we get too far, let's ask an important question: Isn't VBS just for little kids?" Wait for a response, then exclaim, "No way!"
- Ask: "Why should my church have VBS for Students and Adults?" Field responses from everyone and write answers on the dry erase board or easel pad with a marker. Make sure to share the following if not mentioned:
  - To reach students/adults in your city and surrounding communities who don't know Jesus as Lord and Savior.
  - To disciple students/adults in your church family.
  - To create opportunities to connect people to one another and grow in existing relationships.
  - To be in-sync and united in a study across all age groups.
- Say: "Now that we know the 'why,' let's look at the 'when' and 'how.' What are some 'in' and even 'out-of-the-box' ideas for when and how you can plan your Student and Adult VBS?" Field answers and write them on the dry erase board or easel pad with a marker. Include the following if not mentioned:
  - During a traditional VBS week.
  - As a fall retreat, a summer camp, or a weekend conference.
  - Use sessions to prepare volunteers during midweek or Sunday evening services. (This can be January/February or in the 5 weeks leading up to VBS.)
  - Host a parenting seminar that is open to the community.

- Host a daytime event for senior adults in a senior center.
- Inform the conferees that knowing their neighborhood and city culture is vital in planning a Student and Adult VBS. Ask the conferees to consider the rhythms of their community and share examples of when they would or would not schedule their Student and Adult VBS. Field answers from a few volunteers.
- Reassure conferees that there's no "one-size-fits-all" way to schedule VBS! Point them to the *VBS 2026 Adult Leader Guide* for more ideas and practical tips. Say: "It's packed with helpful guidance to get you started!"
- Say: "VBS has no shortage of things to do and one of the first things to do is be prepared." Pretend to search for something as if you have lost it. Ask conferees if anyone has seen your flashlights anywhere?
- Explain that you have three flashlights with words on them that start with *P* somewhere around the room. Invite conferees to search for them until they are found and bring them to you.
- Once the flashlights are found and brought to you, say: "Thank you so much! I could not have done that without you! It helps to be prepared and have great people to help you get ready—just like at VBS! Let's look to see how we can get prepared for the best days ever!"

### 3. Be Prepared (40 minutes)

- Hold up the first flashlight: *Prepare*. Lead the conferees to repeat back loudly: "Be Prepared."
- Say: "Just like you helped me find my flashlights, you are going to need help to make this VBS happen. So how can we help leaders get ready for such an important role? We help them prepare—not just with material or curriculum—but help them prepare their hearts to be ready to be a light. We want Jesus to shine through our leaders!"
- Talk through the following Ps of Preparation:
  - **Prepare Your Heart:**
    - Point to the Bible verse poster (from the *VBS 2026 Visual Pack* or the Student or Adult Leader Kits). Lead the conferees to read it along with you.
    - Remind conferees that the *B* in VBS (Bible) may be the second letter of the title, but it comes first in what we do. The Bible is where we begin and it's where we lay our foundation.
    - Say: "If we are to illuminate Jesus, we point people back to His Word. Where does the *B* sit in the word 'VBS'? (*the center*). Remember, keep God's Word central as you prepare your VBS!"
    - Remind conferees to use the daily Leader Devotions (or "Bible Background" in the Adult Leader Guide) with each session. Encourage them to reflect on each day and read through the Bible passage multiple times leading up to VBS.
    - Guide conferees to pray over every leader at their VBS. Say: "You may not know their names yet, but God does. Any leader that serves at your VBS is because God provided them. Let's pray for God to use their gifts and talents to serve your VBS well."
  - **Prepare Your Head:**
    - Hold up each leader guide for all to see. Explain that leader guide is a great guide and tool. Learn it well! Read the whole thing and do not rush through it. Meditate on each lesson and don't forget to use God's Word with it too.

- Say: “Each theme is so well thought out and prayed over. Our kids need it, our teenagers need it, and our adults of every age and stage of life need it too.”
  - **Prepare for Participants:**
    - Say: “To know how to prepare our leaders, we need to understand who we are leading—our students and adults.”
    - Hold up a *VBS 2026 Student Leader Guide* and turn to page 5.
    - Say: “Let’s begin with students. Page 5 provides a short summary to help leaders understand how students develop, think, and grow spiritually. This information will be vital to help your student leaders lead well and be effective in their teaching and planning.”
    - Explain that for adults, it can be trickier as there is more generational overlap that could attend an Adult VBS.
    - Say: “Let’s identify some common characteristics for all generations of adults.” (*They need relationships and connection with other people; want their work and lives to matter; have daily needs that must be met; want peace in their lives; can be lifelong learners.*) Take a few answers out loud or write them on the dry erase board.
    - Point out there is common ground between us all! The most important one being we are all made by our God and need to know His truth!
    - Say: “Now that we are familiar with our students and adults, let’s prepare to teach them!”
  - **Prepare to Teach:**
    - Say: “The VBS sessions are filled with such great content, and they are so fun for all ages!”
    - Challenge conferees during the month leading up to VBS to read one of the Bible passages each day. Stress that they need to know these passages inside and out to lead students and adults through them.
    - Briefly go over the biblical content. With each day, ask conferees how that Bible passage and daily point can be applied to students and adults.
      - **Day 1 or Week 1—Jesus Is God’s Promised Son**
        - Bible Passage: Jesus Asked Who People Thought He Was (*Matthew 16:13-20*)
        - Spotlight Question & Answer: Who is Jesus? Jesus is the Messiah, the promised Son of God
        - Today’s Point: Jesus is God’s promised Son.
        - Bonus Verse: You are the Messiah, the Son of the living God. *Matthew 16:16*
      - **Day 2 or Week 2—Jesus Is God’s Perfect Son**
        - Bible Passage: The Baptism of Jesus (*Matthew 3:13-17; Mark 1:1-11; John 1:29-34*)
        - Spotlight Question & Answer: Was Jesus an ordinary man? Jesus is the perfect Son of God who came to be the Savior of the world.
        - Today’s Point: Jesus is God’s perfect Son.
        - Bonus Verse: A voice came from heaven: “You are my beloved Son; with you I am well-pleased.” *Mark 1:11*
      - **Day 3 or Week 3—Jesus Is the Powerful Son of God**

- Bible Passage: Jesus Performed Miracles (*Matthew 15:29-39*)
- Spotlight Question & Answer: Was Jesus just a teacher? Everything Jesus said and did showed that He is the powerful Son of God.
- Today's Point: Jesus is the powerful Son of God.
- Bonus Verse: Jesus came near and said to them, "All authority has been given to me in heaven and on earth." *Matthew 28:18*
- **Day 4 or Week 4—Jesus Is the Proven Son of God**
  - Bible Passage: Jesus Died and Rose to Life (*Mark 14:43–16:7*)
  - Spotlight Question & Answer: Was Jesus just someone who lived a long time ago? Jesus lived, died, and rose to life again to be our Savior, now and forever.
  - Today's Point: Jesus is the proven Son of God.
  - Bonus Verse: When the centurion ... saw the way he breathed his last, he said, "Truly this man was the Son of God." *Mark 15:39*
- **Day 5 or Week 5—Jesus Is God's Plan for Forgiveness**
  - Bible Passage: Peter Preached About Jesus (*Acts 2*)
  - Spotlight Question & Answer: Why do I need to respond to Jesus? Jesus is the only way to receive God's forgiveness.
  - Today's Point: Jesus is God's plan for forgiveness.
  - Bonus Verse: Repent and be baptized, each of you, in the name of Jesus Christ for the forgiveness of your sins, and you will receive the gift of the Holy Spirit. *Acts 2:38*
- Remind the conferees how important it is for leaders to prepare for their sessions. They should encourage leaders to pray daily over each session and to trust God in their abilities to teach.
- Say: "Now that we know WHAT we are teaching, let's prepare WHERE we will be teaching."
- **Prepare Your Room:**
  - Instruct conferees to get on their feet. Say: "It's time to ILLUMINATE the room! Let's pretend we are holding flashlights, and we need to light up the space around us!"
  - Lead conferees to do the following actions with each prompt:
    - Let's light up the ceiling! (*Hold both hands up as high as you can on your tiptoes.*)
    - Let's light it up, side to side. (*Stretch both arms out to the left, then right, and repeat moving at different speeds.*)
    - We cannot forget the floor! (*Stretch both hands down as low as you can go and hold it for a few seconds.*)
  - Say: "Well done! I know that was hard work, but as we prepare our spaces, let's think about some things we need to ask ourselves." Mention the following questions:
    - Where is my space located?

- How many people should I expect to attend?
  - Can I add/remove items from the walls?
  - Can I move furniture?
  - Is there a dry erase board or TV for slides?
  - Can I play music?
  - Do I know where my supplies are?
  - Do I have enough Bibles?
  - Do I have safety and security procedures in place? (This is important if adults are sharing the same areas as kids/students such as restrooms and hallways.)
- Say: “This is a great place to begin as you think about your potential space. Not every room will be the ideal environment, but we can make any space a place to help our people feel welcome and invited!”
  - Remind conferees that it’s easy to forget small details in planning, but that is why you are here so you can plan and prepare to SHINE at VBS time!
  - Offer the following tips to help students and adults feel comfortable, welcomed, and ready to engage during VBS:
    - Decorate your teaching space. This brings the whole VBS theme to life and helps everyone—students and adults—feel the excitement the moment they walk in! A vibrant, creative environment grabs attention, sparks curiosity, and gets people ready to shine a light on God’s Word. It shows that you’ve put thought and heart into their experience, helping guests feel welcomed and valued. When your space shines, your message can SHINE even brighter—making VBS unforgettable! (Refer conferees to page 6 in the Adult Leader Guide and the *Decorating Made Easy* book to help with inspiration and creativity.)
    - Make learning names a priority. Everyone wants to feel noticed and valued. Make it a priority to learn everyone’s names as quickly as you can. Use name tags to help you match faces with names and build connections more easily.
    - Aim for multiple connection points. It’s important for you, as the leader, to make a personal connection, but you shouldn’t be the only one VBS participants connect with. Help introduce them to others in your church who share similar interests so they can build multiple meaningful relationships, not just one. This deepens their sense of belonging and strengthens their connection to your church community.
    - Watch your language. People who aren’t familiar with church may not understand “churchy” words. Be mindful of terms like *sanctification* or *repentance*. Assume some will not know what they mean and offer a simple explanation whenever you use them. Always provide context and background as you teach so no one feels singled out or uncomfortable asking questions. This helps create a welcoming, accessible environment for everyone.

- Think about everyone. Students and adults come with different needs, so create a space that reflects that. Provide extra room for larger individuals, ensure wheelchair-accessible seating, and consider an interpreter for language barriers or a “buddy” for participants with special needs. A willingness to adapt and make thoughtful accommodations helps everyone feel welcomed from the very start.
- Say: “Do you feel a bit more prepared? Are you ready to help get your leaders prepared for VBS 2026? Good! Now that our leaders are prepared, let’s help them plan their VBS sessions.”

#### 4. Make a Plan (25 minutes)

- Hold up the second flashlight: *Plan*. Direct conferees repeat back loudly, “I’ve got a plan!”
- Explain that there are five elements in the Adult and Student teaching plans.
  - For Students:
    - Open
    - Motivate
    - Examine
    - Gospel Focus
    - Apply
    - Rotations
  - For Adults:
    - Arrival
    - Engage
    - Examine
    - Gospel Focus
    - Apply
- Guide conferees through each of the five key elements, highlighting them in the leader guides so everyone knows exactly where to find what they need.
  - **Open or Arrival: 15–20 Minutes**
    - This time gives everyone a chance to connect and start building relationships. Use it to introduce people with similar interests and help spark new conversations. Play some background music and offer snacks and drinks to create a warm, welcoming atmosphere.
    - This is also the perfect moment for the leader to kick off the session and welcome everyone. You can even add a quick game or a time of worship through song—whatever helps set the tone for the rest of your time together.
  - **Motivate or Engage: 15–20 Minutes**
    - This is where you introduce the theme for the session. Start with an intriguing discussion question to spark conversation and get people talking.
    - Incorporate interactive elements or form smaller discussion circles if you have more than 30 participants. If you don’t capture interest early, attention spans will drop quickly—regardless of age—so make this moment count!
  - **Examine: 35–50 Minutes**
    - Now we are diving deep into Scripture. Invite someone (don’t volunteer someone) to read the passage. Walk through the teaching points and

engage with the group. Ask the questions provided and be willing to wait for answers even if it's awkward.

- Here are some bonus tips to help you lead through Examine:
  - **Relax**—Don't approach teaching with a tight or anxious mindset. When we're tense, it shows through our actions and reactions. Take a few minutes beforehand to pray and establish a calming routine that clears your mind and helps you focus.
  - **Don't read from the book**—This isn't a bedtime story. We want people to be engaged and when someone reads directly from the book for every point, it looks unprepared. Write or type out notes even if you are taking the points directly from the material. This will help you be more polished and so you can engage more with the group.
  - **Build relationships**—One of the best ways to connect with your group is by investing in relationships outside of teaching time. Talk with them, ask about their lives, and show genuine interest in their school, work, or daily experiences. When people feel cared for, they're far more engaged in what you have to share.
  - **Don't lecture**—This isn't meant to be a one-way presentation. Ask questions that spark discussion and guide the conversation like a steady captain at the helm. If things drift off course, gently steer them back. Use open-ended questions that cannot be answered by a simple yes or no, embrace moments of (awkward) silence, and resist the urge to answer your own questions.
  - **Be flexible**—Stay willing to adjust your plans when things shift unexpectedly. Flexibility creates a smoother, more enjoyable experience for both you and your group.
- **Apply & Gospel Focus: 10–15 Minutes**
  - Everything we teach should connect to real life—Jesus modeled this, and we should follow His example. Help your group see how each theme and Scripture truth applies to their everyday world, from teens to senior adults. Remember, it is not guaranteed that everyone in the room is a follower of Jesus, so treat each session as a chance to share the gospel.
  - Each lesson includes a “Gospel Focus” (point out the Gospel Focus icon in the leader guide), giving you a natural moment to point the conversation toward Jesus. Don't miss these powerful opportunities!
- **Rotations**
  - VBS shouldn't be all sit-down teaching—mix in moments to move, play, and create!
  - Students have built-in rotations that pair with the Bible Study on page 4 of the Student Leader Guide.
  - Adults need fun and creativity too! Use the *VBS 2026 Recreation Rotation Cards*, *VBS 2026 Snack Recipe Cards*, and Printable Items from the Kits to keep every session lively and engaging.
- Say: “We are now prepared and planned. So, what was the last one again?”

##### 5. Packed with Plentiful Piles of To Do's (5 minutes)

- Hold up the third flashlight: *Packed with Plentiful Piles of To Do's*. Direct conferees to read it together.

- Locate the final (hidden) flashlight: *Phew!* Laugh and remind the conferees while they are feeling more prepared and planned, they still have plenty to do!
- Point out that the leader guides and the downloadable and printable content have so many options to choose from. The *VBS 2026 Administrative Guide* also has many valuable tools to help with registration and follow-up connections after VBS is over.
- Invite conferees to share one thing they are still nervous about in all their “To Do’s.”
- Remind everyone that this is not their VBS nor their churches. This is God’s VBS, so trust Him!

**6. Closing (5 minutes)**

- Thank everyone for attending.
- Invite them to pray silently for one minute over their VBS and the thing they mentioned being nervous about. Pray over their volunteers and future attendees.
- After one minute, close by praying over the conferees. Then dismiss.

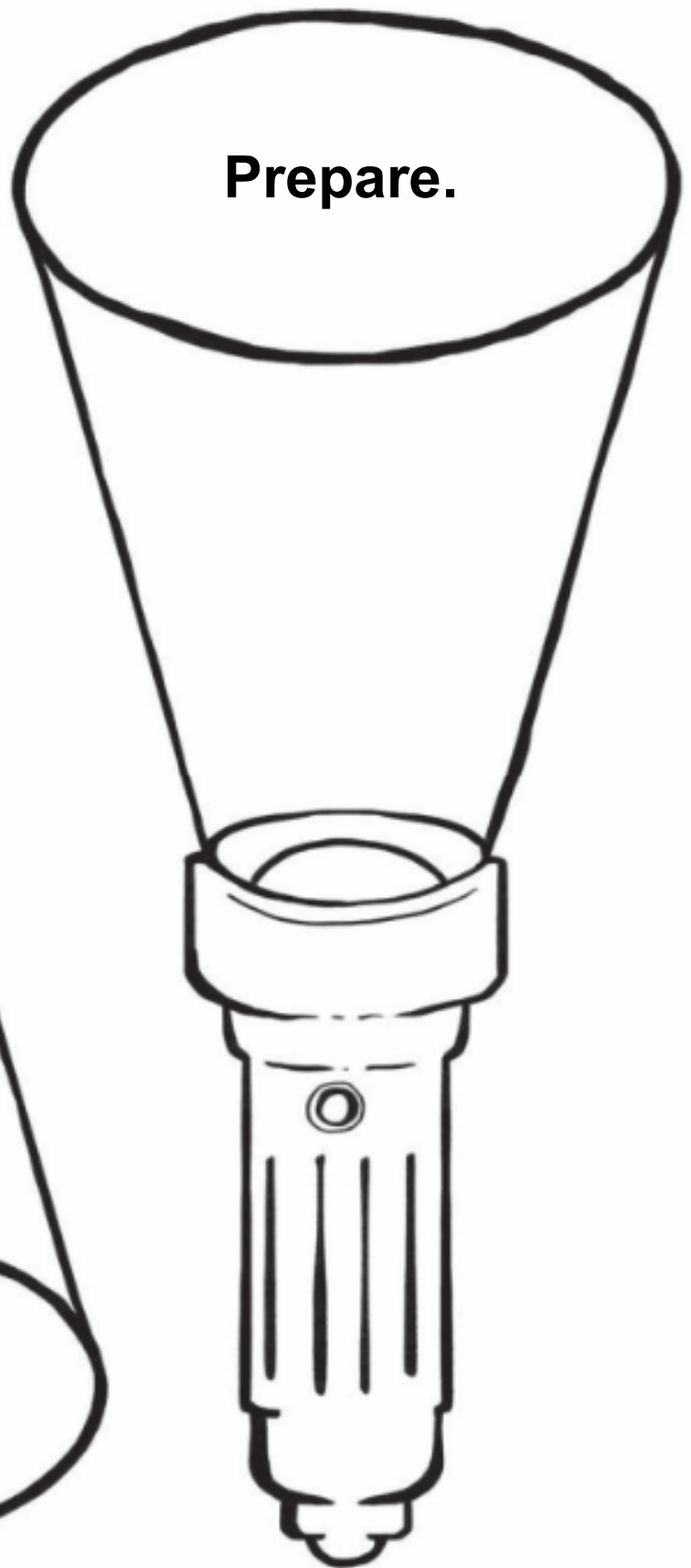
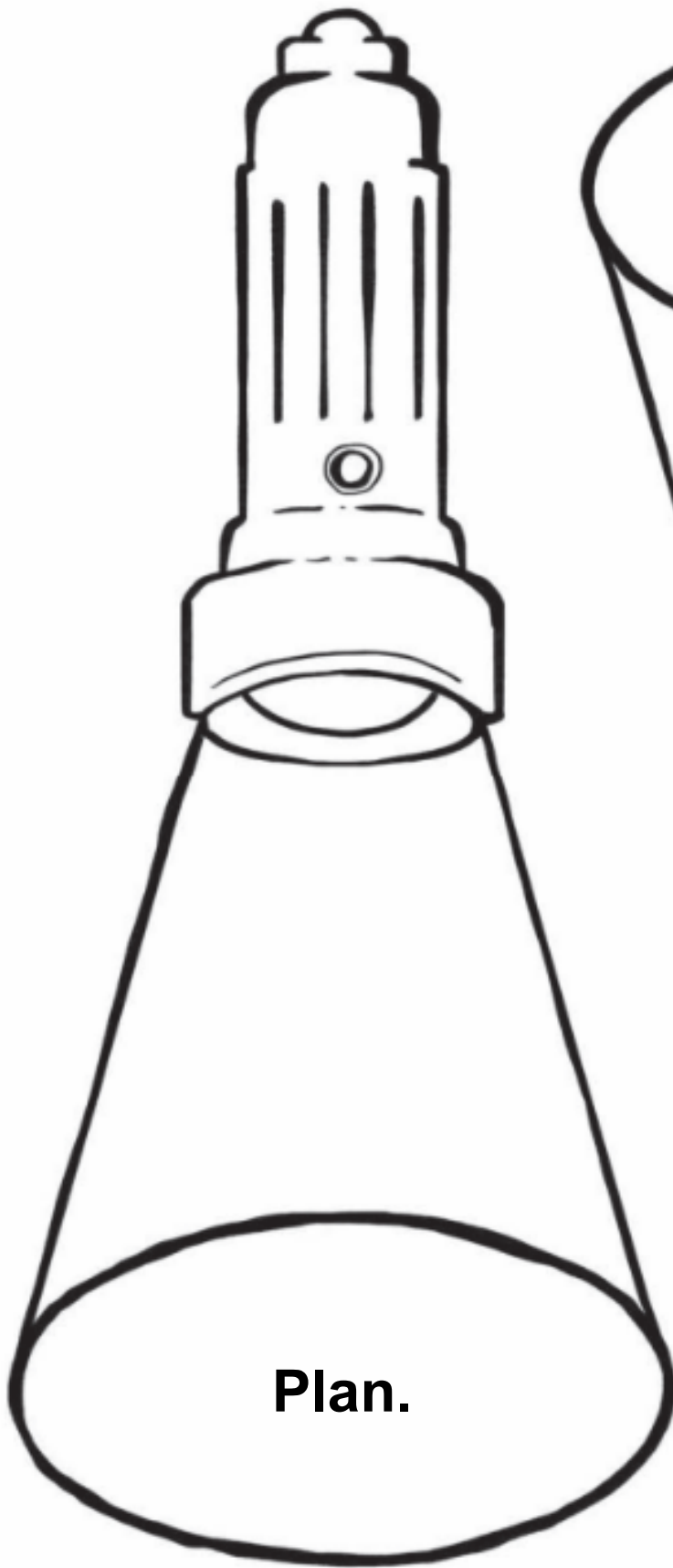

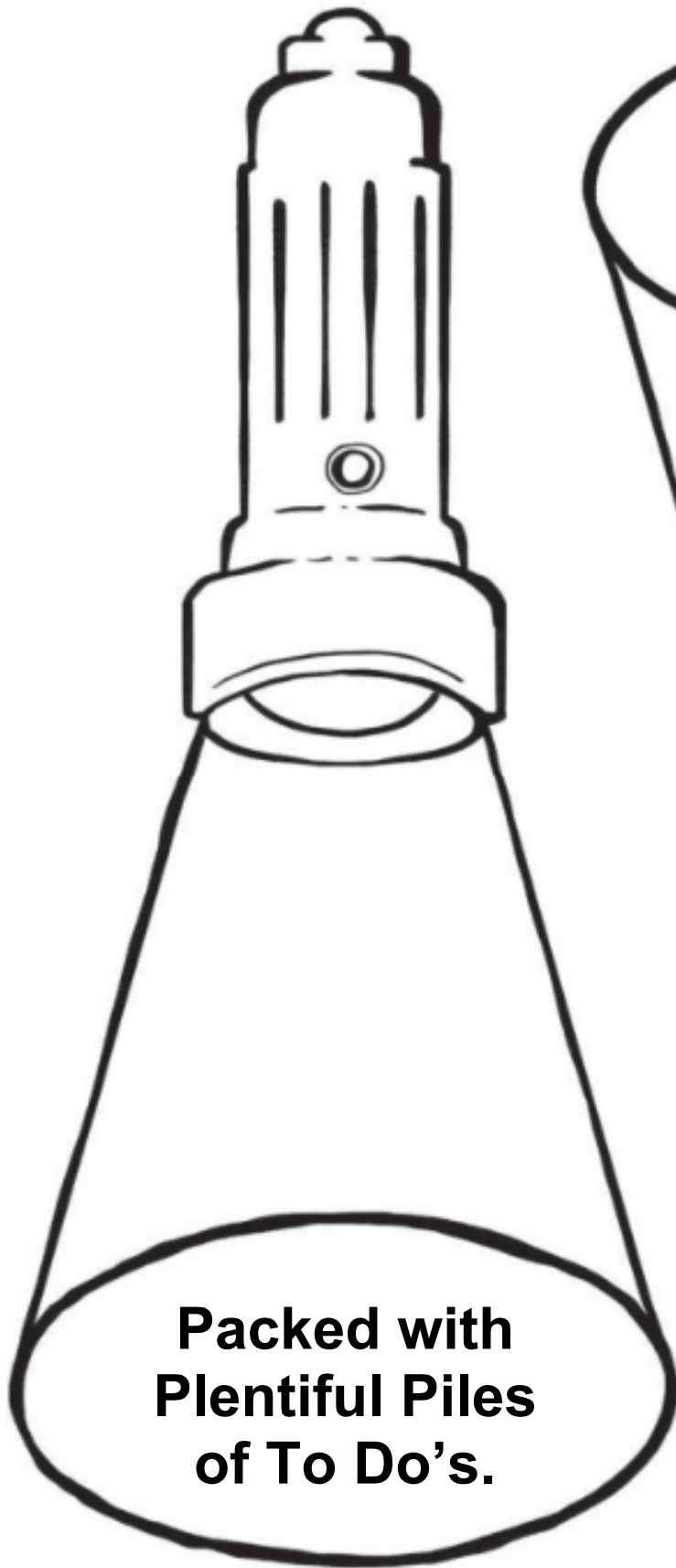

**Packed with  
Plentiful Piles  
of To Do's.**

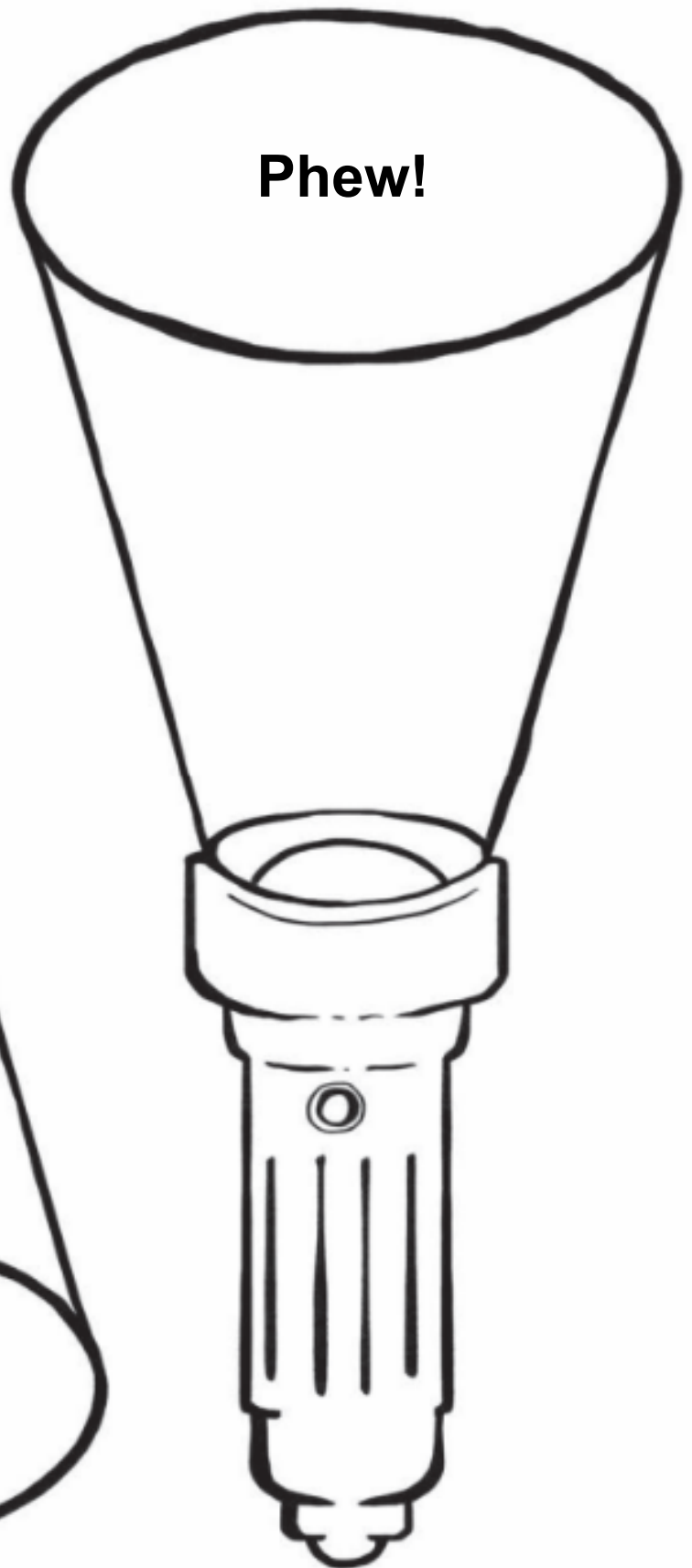

**Phew!**